

# EE 570: Location and Navigation

## INS/GPS Integration

Aly El-Osery<sup>1</sup>   Stephen Bruder<sup>2</sup>

<sup>1</sup>Electrical Engineering Department, New Mexico Tech  
Socorro, New Mexico, USA

<sup>2</sup>Electrical and Computer Engineering Department, Embry-Riddle Aeronautical University  
Prescott, Arizona, USA

April 15, 2014

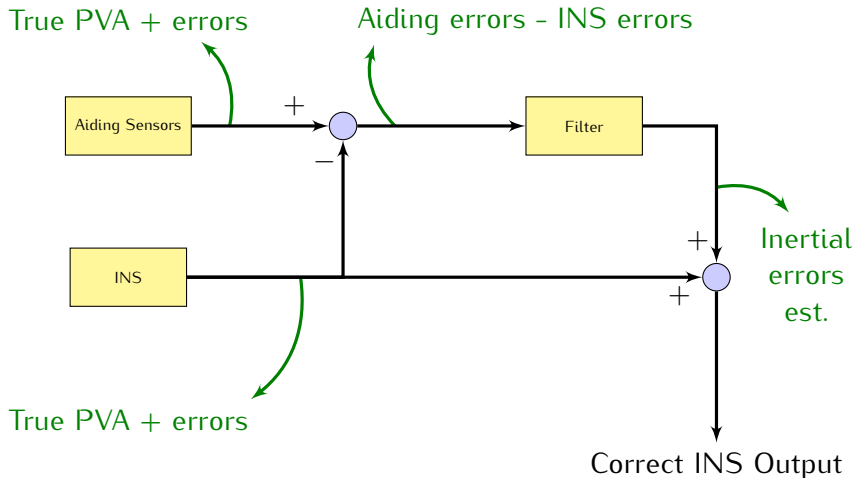

If error estimates are feedback to correct the INS mechanization, a reset of the state estimates becomes necessary.

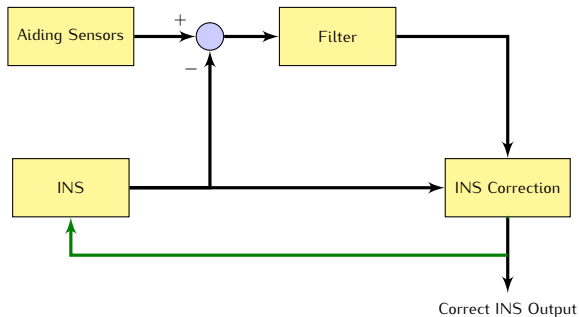

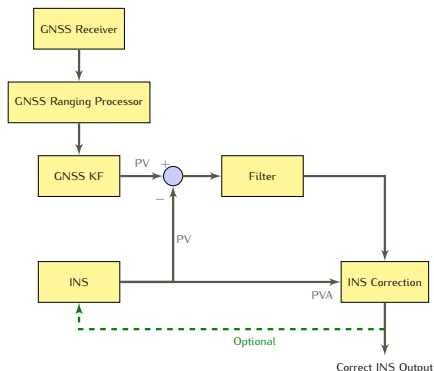

- Simple
- Cascade KF therefore integration KF BW must be less than that of GNSS KF (e.g. update interval of 10s)
- Minimum of 4 satellites required

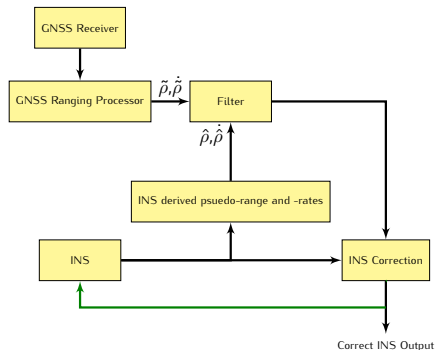

- No cascade KF
- KF BW must be kept less than the GNSS tracking loop
- Does not require 4 satellites

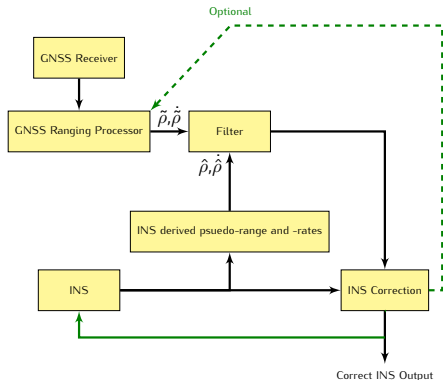

- No cascade KF
- KF BW must be kept less than the GNSS tracking loop
- Does not require 4 satellites

$$\vec{z}_k^e = \begin{pmatrix} \tilde{\vec{r}}_{GPS} - \hat{\vec{r}}_{eb}^e \\ \tilde{\vec{v}}_{GPS} - \hat{\vec{v}}_{eb}^e \end{pmatrix} \quad (1)$$

$$\mathbf{H} = \begin{pmatrix} 0_{3 \times 3} & 0_{3 \times 3} & \mathbf{I}_{3 \times 3} & 0_{3 \times 3} & 0_{3 \times 3} \\ 0_{3 \times 3} & \mathbf{I}_{3 \times 3} & 0_{3 \times 3} & 0_{3 \times 3} & 0_{3 \times 3} \end{pmatrix} \quad (2)$$

Theoretically, the lever arm from the INS to the GNSS antenna needs to be included, but in practice, the coupling of the attitude errors and gyro biases into the measurement through the lever arm is weak.

The computed INS psuedo-range and rates with respect to the  $j$ th satellite,  $\hat{\rho}_j$  and  $\dot{\hat{\rho}}_j$

$$\hat{\rho}_j = \sqrt{[\vec{r}_{es,j}^e - \hat{\vec{r}}_{eb}^e]^T [\vec{r}_{es,j}^e - \hat{\vec{r}}_{eb}^e]} + \delta \hat{\rho}_{rc,j} \quad (3)$$

$$\dot{\hat{\rho}}_j = \vec{u}_j^T [\vec{v}_{s,j}^e - \hat{\vec{v}}_{eb}^e]^T + \delta \dot{\hat{\rho}}_{rc,j} \quad (4)$$

where

$$\vec{u}_j = \frac{\vec{r}_{es,j}^e - \hat{\vec{r}}_{eb}^e}{\|\vec{r}_{es,j}^e - \hat{\vec{r}}_{eb}^e\|} \quad (5)$$



Pseudo-ranges are used instead of XYZ.

$$\vec{z} = \begin{pmatrix} \vec{z}_\rho \\ \vec{z}_{\dot{\rho}} \end{pmatrix} \quad (6)$$

where

$$\vec{z}_\rho = (\rho_{gps,1} - \hat{\rho}_1, \rho_{gps,2} - \hat{\rho}_2, \dots, \rho_{gps,n} - \hat{\rho}_n) \quad (7)$$

$$\vec{z}_{\dot{\rho}} = (\dot{\rho}_{gps,1} - \dot{\hat{\rho}}_1, \dot{\rho}_{gps,2} - \dot{\hat{\rho}}_2, \dots, \dot{\rho}_{gps,n} - \dot{\hat{\rho}}_n) \quad (8)$$

$$\vec{x}(t) = \left( \delta\psi_{eb}^e \quad \delta\vec{v}_{eb}^e \quad \delta\vec{r}_{eb}^e \quad \vec{b}_a \quad \vec{b}_g \quad \delta\rho_{rc} \quad \delta\dot{\rho}_{rc} \right)^T \quad (9)$$

$\rho_{gps,j}$ , and  $\dot{\rho}_{gps,j}$  and  $\hat{\rho}_j$ , and  $\dot{\hat{\rho}}_j$  are the pseudo-ranges and rates obtained from the GNSS and INS, respectively, for the  $j$ th satellite. These equations are non-linear and an EKF needs to be used.  $\delta\rho_{rc}$  and  $\delta\dot{\rho}_{rc}$  are the clock bias and drift.

$$\mathbf{H} = \begin{pmatrix}
 0_{1 \times 3} & 0_{1 \times 3} & -\vec{\mathbf{u}}_1^T & 0_{1 \times 3} & 0_{1 \times 3} & 1 & 0_{1 \times 3} \\
 0_{1 \times 3} & 0_{1 \times 3} & -\vec{\mathbf{u}}_2^T & 0_{1 \times 3} & 0_{1 \times 3} & 1 & 0_{1 \times 3} \\
 \vdots & \vdots & \vdots & \vdots & \vdots & \vdots & \vdots \\
 0_{1 \times 3} & 0_{1 \times 3} & -\vec{\mathbf{u}}_n^T & 0_{1 \times 3} & 0_{1 \times 3} & 1 & 0_{1 \times 3} \\
 \hline
 0_{1 \times 3} & -\vec{\mathbf{u}}_1^T & 0_{1 \times 3} & 0_{1 \times 3} & 0_{1 \times 3} & 0_{1 \times 3} & 1 \\
 0_{1 \times 3} & -\vec{\mathbf{u}}_2^T & 0_{1 \times 3} & 0_{1 \times 3} & 0_{1 \times 3} & 0_{1 \times 3} & 1 \\
 \vdots & \vdots & \vdots & \vdots & \vdots & \vdots & \vdots \\
 0_{1 \times 3} & -\vec{\mathbf{u}}_n^T & 0_{1 \times 3} & 0_{1 \times 3} & 0_{1 \times 3} & 0_{1 \times 3} & 1
 \end{pmatrix} \quad (10)$$

In deeply coupled GPS/INS integration

- the integration architecture utilizes the INS to aid in the tracking loops,
- allows fast acquisition,
- performance improvement with low signal-to-noise environments, and
- more resistance to jamming.

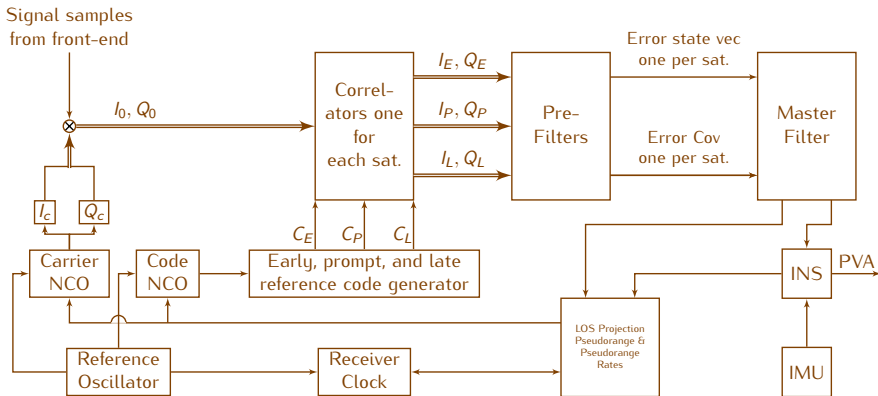

Are the states observable given a certain set of measurements?  
The system is observable if the observability matrix

$$\mathcal{O}(k) = \begin{bmatrix} \mathbf{H}(k - n + 1) \\ \mathbf{H}(k - n - 2)\Phi(k - n + 1) \\ \vdots \\ \mathbf{H}(k)\Phi(k - 1) \dots \Phi(k - n + 1) \end{bmatrix} \quad (11)$$

where  $n$  is the number of states, has a rank of  $n$ . The rank of  $\mathcal{O}$  is a binary indicator and does **not** provide a measure of how close the system is to being unobservable, hence, is prone to numerical ill-conditioning.

In addition to the computation of the rank of  $\mathcal{O}(k)$ , compute the Singular Value Decomposition (SVD) of  $\mathcal{O}(k)$  as

$$\mathcal{O} = U\Sigma V^* \quad (12)$$

and observe the diagonal values of the matrix  $\Sigma$ . Using this approach it is possible to monitor the variations in the system observability due to changes in system dynamics.

In Many cases the data from the aiding sensor may get corrupt and even not available. In those cases we can't use those measurements in the Kalman filter. Therefore

- 1 Set the Kalman gain to zero, or
- 2 Do not run the state or error covariance update steps.